

# ARBOGA - DARENTH

## OPERATING INSTRUCTIONS

### SWARF CRUSHER TYPE KB49

### ELECTRIC DRIVE

**Customer:** .....

**Order No.:** .....

**Manufacturing No.:** .....

**Delivery date:** .....

---

## ARBOGA-DARENTH AB

Box 1022, SE-732 27 ARBOGA, Sweden, Tel +46 (0)589 - 610 200, Fax +46 (0)589 - 610 210

E-mail: [info@arbogadarenth.se](mailto:info@arbogadarenth.se)

## Content

---

Foreword .....	2
Guarantee .....	3
Warnings .....	4
Safety regulations .....	5
Working method - figure 1 .....	6
Lifting instruction - figure 2.....	7
Installation - figure 3 .....	8
Assembly instructions .....	9
Automatic bar end rejector.....	10
Greasing .....	10
Spare parts .....	11
Drawing with pos.nos. ....	12-13
Spare parts – to be stocked .....	14-15
Trouble-shooting .....	16
Examples of erection.....	17

Enclosure

## **Foreword**

ARBOGA-DARENTH Swarf Crushers guarantee good design, quality components and skilled labour plus years of experience in swarf handling and swarf crushing. All these abilities have been used to design a product with high reliability and long service life. We are convinced that your experiences will confirm your choice of ARBOGA-DARENTH Swarf Crusher.

Length of life and reliability can, as with any machine tool, be prolonged with correct installation and correct maintenance. It pays off to follow our advice for maintenance.

This maintenance manual consists of instructions for your new ARBOGA-DARENTH Swarf Crusher. It also contains greasing instructions, spare parts list with exploded view and a simple schedule for trouble-shooting.

ARBOGA-DARENTH Swarf Crushers are normally used in swarf handling systems which we design, sell and install.

All Swarf Crushers which leave our works are checked and do not need any additional maintenance other than stated in this manual.

For orders of spare parts and if you want to contact our engineers please find our phone number and address at the front page of this instruction.

## Guarantee

All products from ARBOGA-DARENTH are guaranteed free from any fault in material and labour during a period of one year. One year consists of 365 calendar days or 1800 hours which ever occurs first. The guarantee period for our products starts the day the equipment is sent to the client and continues during one year as earlier described. This is due if our maintenance and control recommendations are followed.

The guarantee is not valid for incorrect erection, misuse, incorrect maintenance or if maintenance is not made due to our recommendations and accepted industry practice.

During the guarantee period and after written notice to us, we guarantee that all parts manufactured in our plant which are faulty regarding material or labour shall be replaced. We give no further guarantee either written or verbal for costs except material and man labour.

### **This guarantee or other guarantees from us do not cover:**

1. Damage after the guarantee period is ended.
2. Damage caused by chemical reactions or wear due to the detail has been submitted to external influences.
3. Equipment damaged at delivery or by accidents.
4. Damage through misuse, incorrect use or feeding of the crusher or if recommended maintenance is not followed.
5. Damage to equipment which have been repaired or changed by others than by the one who has been acknowledged as our sole representative.
6. Wear parts.

The capacity depends on volume/weight of material, size and shape of the chips. The capacity and residual humidity data specified in our order confirmation are valid for your crusher.

## Warnings

It is imperative for the reasons of safety to read these warnings and understand them in detail. If you not understand them, you must consult ARBOGA-DARENTH AB.

1. The owner of this equipment is responsible to install and operate the crusher in conformance with applicable federal, state and local regulations and to instruct the operating and maintenance personnel in safe operating procedures.
2. Never inspect, adjust, maintain or remove any material from the crusher or feed the hopper while the feeder arm is turning.
3. Electrically lock the motor and mechanically prevent it from rotating during maintenance or inspection. If you do not understand how to do this contact ARBOGA-DARENTH AB.
4. Before attempting to clear a clogged or jammed hopper or crusher chamber, or perform any inspection or maintenance, the motor and the master control must be de-energised and locked-out and fuses removed so that the crusher cannot be accidentally started.
5. Never, under any conditions, should any stick, rod or similar device be inserted into the hopper or discharge opening while the crusher motor is energised or the feeder arm is turning.
6. Never, under any conditions, should any person reach or look inside of the hopper or discharge opening while the crusher motor is energised or the feeder arm is turning.
7. Never, under any circumstances, walk or stand on the feeder arm unless the motor is de-energised and the feeder arm is locked in place. If the feeder arm were to turn, it could cause injury or death.
8. Never, under any circumstances, use this crusher for any purpose other than specified above. Do not make any changes or additions to the crusher, hopper, discharge opening, guards, base plate or drive motor unless approved by ARBOGA-DARENTH AB.
9. If your crusher was purchased as used equipment, make sure it is used for the original intended use and that requisite guards and interlocks are installed to latest regulations.
10. Never feed combustibles, explosives, drosses, petrochemicals or dust producing materials into the crusher. The crusher should be well ventilated to remove dust concentrations. Failure to comply with this warning can cause fire or explosions resulting in injury or death.
11. Every employee who operates or supervises the operation or maintenance of this crusher should read in detail and understand this warning.
12. This warning should be posted on the company bulletin board or on a wall that is accessible to and used for the purpose of posting company employee data.

## **Safety regulations**

- Electrical and hydraulical installations have to be done by qualified personnel only.
- At connection of voltage feed as well as at service and maintenance work on the crusher the circuit breaker must be off.
- Test the emergency stop at installation and always when maintenance and service have been done.
- The crusher must not be operated with the covers removed.
- Protective goggles must be used for work around the crusher.
- Materials able to crush are all types of steel swarf, aluminium alloys and brass alloys, if any other material please ask ARBOGA-DARENTH.
- The data sheet from the coolant supplier must be studied as parts from coolant can cause allergic reactions.

### **WARNING!**

The floor around the crusher might get slippery from coolant getting outside the machine.

## Working method

The swarf is fed into the upper hopper (a) of the crusher. On the sides of the lower hopper (g) are bolted angled cutters (b). On top of the revolving shaft there is a feeding arm (c) with hard-welded cutters. On the shaft there is a rotating crusher head (d) and an outer stationary crusher ring (e). The swarf is broken up in short pieces. The swarf is fed successively down through the crusher chamber, where the fine crushing takes place in the lower part. After completed crushing the swarf is discharged through a chute (h) in the frame. It is important that the hopper always is well filled up, otherwise it can happen that long swarf can go through the crushing tools. To prevent solid parts getting jammed in the crusher it is equipped with bar end rejector (f).

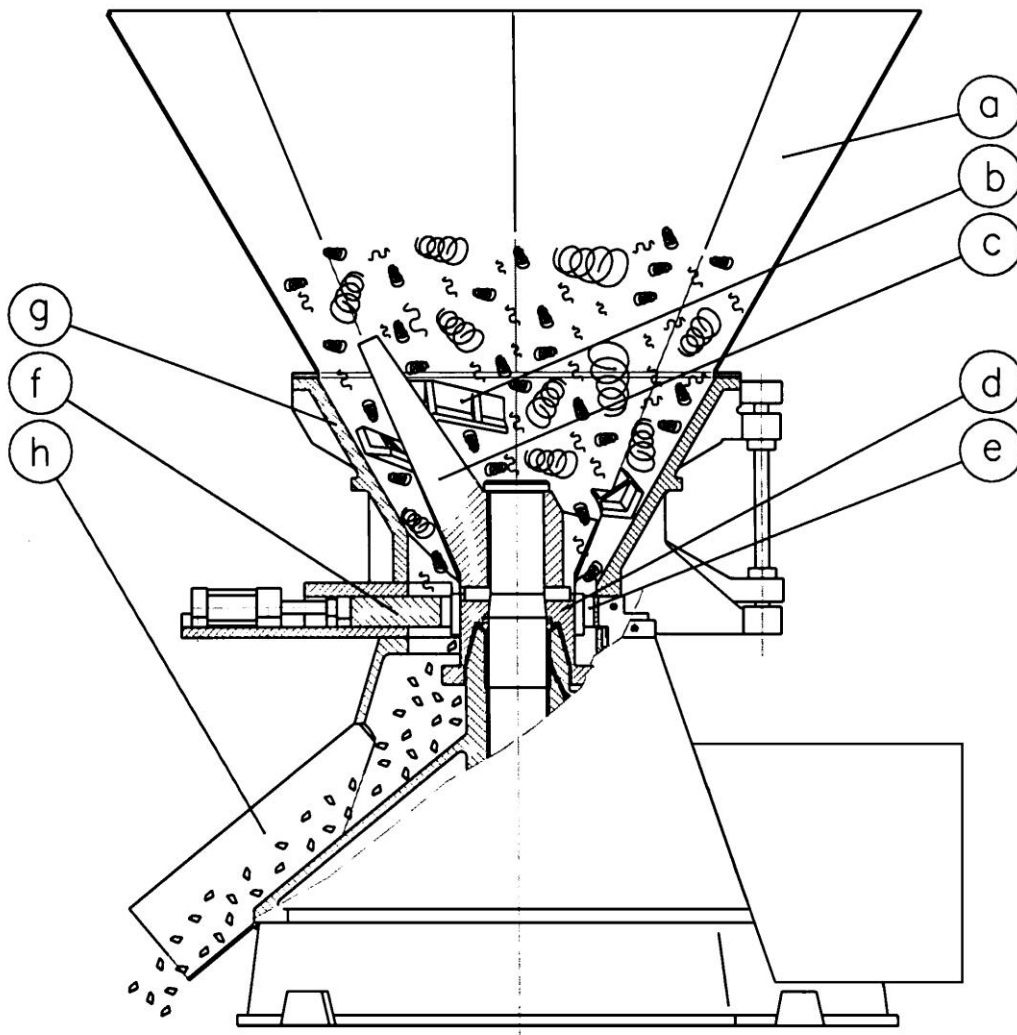

Figure 1

## Lifting instruction

Lift the crusher by crane. Remove the upper hopper and place 4 eye bolts (M24) in the lower hopper.

Place a 4-part chain of approved quality and strength in the eye bolts.

Weight 6500 kg

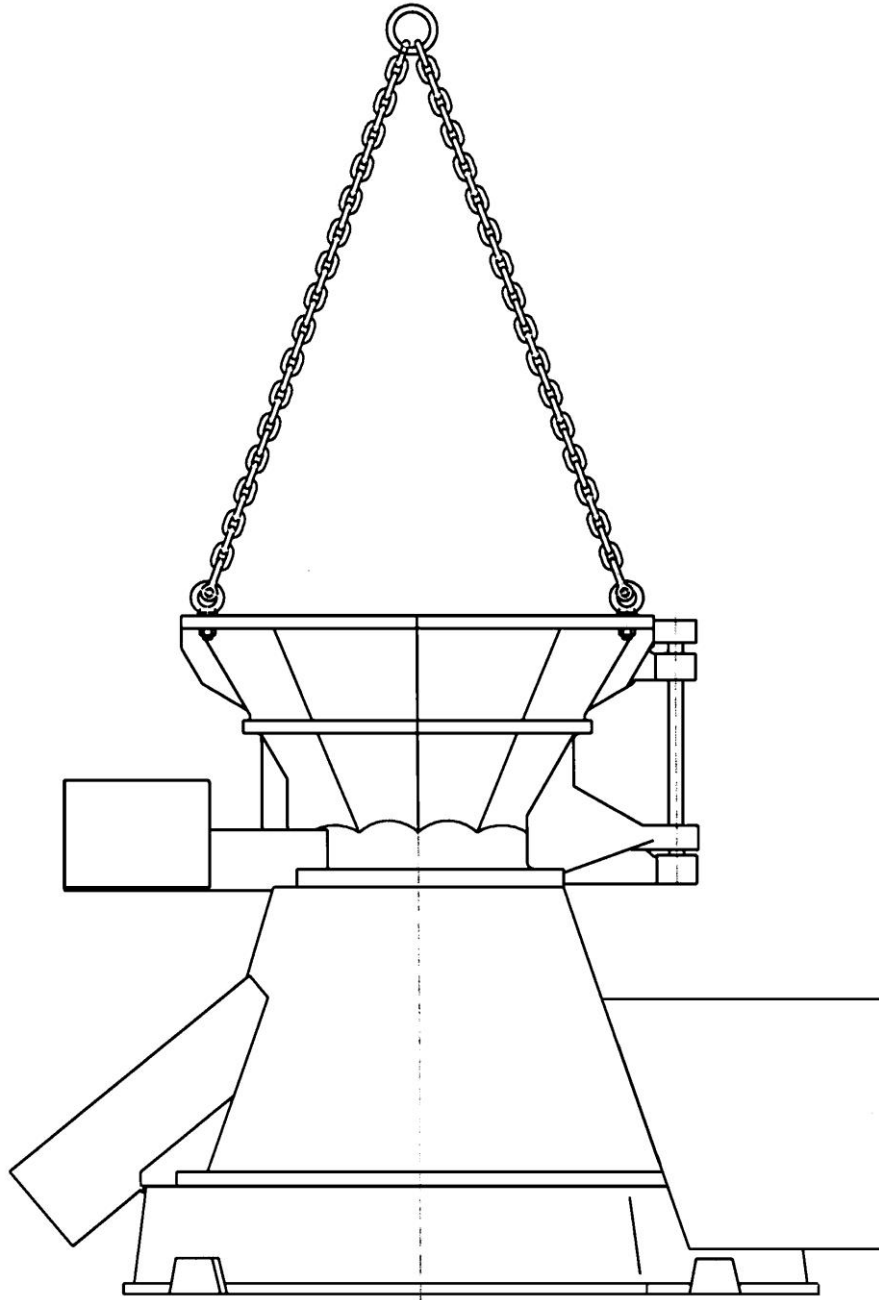

*Figure 2*

## Installation

Figure 3 shows the main dimensions of the crusher.

The crusher must be installed on a stable and plane foundation.

Secure the crusher with embedded anchor screws (M30), or with chemical anchor screws (M30).

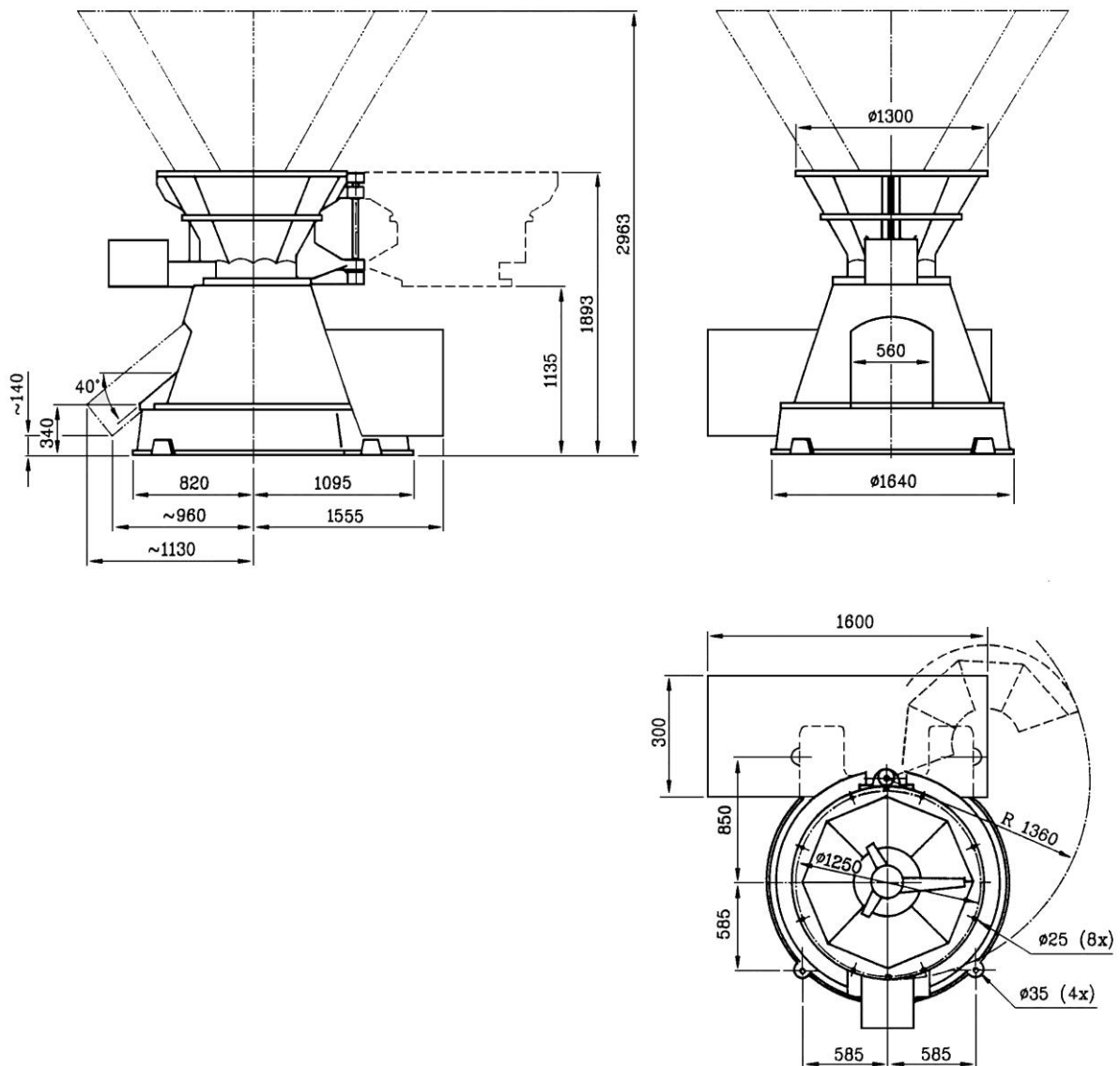

Figure 3

## **Assembly instructions**

### **Cutter**

1. Turn off the circuit breaker.
2. Remove the upper hopper.
3. Unscrew one cutter from the outside of the hopper.
4. Re-assemble the corresponding new cutter.
5. Turn the crusher arm around so that the other cutters are free.
6. Remove the other cutters and replace them with new.
7. Be careful to re-assemble the corresponding cutter in its correct place. (See page 14, Pos 95)
8. Turn the crusher arm around and check that it is clear from the cutters, 2-3 mm is a suitable distance between crusher arm and cutters.
9. Re-assemble the upper hopper.
10. Turn on the circuit breaker.

### **Crusher arm**

1. Turn off the circuit breaker.
2. Remove the upper hopper.
3. Disassemble the washer on the shaft holding the crusher arm.
4. Place 2 eye bolts (M16) in the crusher arm.
5. Lift the crusher arm.
6. Place the new crusher arm on the shaft.
7. Re-assemble the washer.
8. Re-assemble the upper hopper.
9. Turn on the circuit breaker.

### **Crusher ring and crusher head**

1. Turn off the circuit breaker.
2. Remove the upper hopper.
3. Disassemble the washer on the shaft holding the crusher arm
4. Place 2 eye bolts (M16) in the crusher arm.
5. Lift the crusher arm.
6. Remove the lower hopper.
7. Lift the crusher ring.
8. Remove the segment from the bar end rejector.
9. Lift the crusher head.
10. Place the new crusher head with a new packing on the shaft.
11. Assemble the new segment in the bar end rejector.
12. Place the new crusher ring in the groove.
13. Secure the crusher ring with the key.
14. Check that the crusher head revolves.
15. Re-assemble the lower crusher hopper and tighten with silicone packing.
16. Put the keys in the shaft and the crusher head.
17. Re-assemble the crusher arm on the shaft.
18. Re-assemble the upper hopper.
19. Turn on the circuit breaker.

## Automatic bar end rejector

If the crusher is overloaded, i.e. if solid parts are jammed in the lower tools, the electronic torque limiter switches off the motor. A hydraulic cylinder pulls one segment of the crusher ring back and the crusher reverses for about 3 secs. Solid parts and swarf can then pass through the crushing tools. After reversing the crusher starts automatically.

If an uncrushable solid part drops down into the hopper, the reversing action is repeated until the protective motor switch shuts off. The object that has stopped the crusher should be removed before the protective motor switch is put back into operation.

### **CAUTION!**

Before examination, the main switch must be turned off and locked so that the crusher can not start involuntarily while you are working with it.

## Greasing

The gear wheels and all bearings are lubricated from an oil lubricator, see enclosure.

Check daily that oil is dripping on the oil sight glass in the oil lubricator. In case oil drip in lubricator is diminishing, dismantle support fitting, remove the filter and clean it.

The oil level must be checked when the machine is inoperative through the oil level glasses on the base plate of the crusher. Oil fill is made through the inspection cover on the side of the crusher, capacity ca 40 litre. Oil: Statoil "Loadway" EP 220 or some corresponding oil.

When the crusher has been in operation for appr. 30 days, the oil is changed and thereafter once a year at 8 hour operation. When filling new oil after oil change, the oil lubricator must also be filled.

If the crusher is placed out of doors or premises where the temperature can be very low, the oil must be changed to a thinner oil.

**Note!** Before the crusher is being used after all long standstills, the motor of the lubricator should be run separately with the main motor disconnected for about 30 min. enabling oil to find its way to all lubrication points. If the crusher is in use everyday it is not necessary to make mentioned precautionary measures.

## Bar end rejector

The greasing of the bar end rejector is to be done with grease through 2 nipples. These are situated on the crusher hopper, one on each side of the bar end rejector.

Greasing interval: every 14<sup>th</sup> day at 1-shift operation and after longer standstills.

## Spare parts list

**NB!** When ordering spare parts, please specify the following data:

- Type
- Designation
- Serial number
- Article number

Pos	Article No.	Designation	Qty	Unit
2	941406	Bushing		Pce
3	981407	Wearing plate		Pce
4	941401	Base cover		Pce
5	970393115	O-ring		Pce
9	941405	Bushing		Pce
10	941415	Bushing		Pce
15	941416	Wearing plate		Pce
17	921126	Bevel gear wheel		Pce
18	941411	Sleeve		Pce
21	981408	Wearing plate		Pce
22	941404	Shaft		Pce
28	941412	Bevel gear wheel, small		Pce
74	941410	Packing		Pce
75	901415	Coarse crusher head		Pce
	901406	Fine crusher head		Pce
76	981404	Key	2 pcs	Set
85	901416	Shaft		Pce
89	921134	Knob	2 pcs	Set
90	921133	Door	2 pcs	Set
91	901405	Feeder arm, standard		Pce
92	941423	Spacer		Pce
95	901424 See page 14	Cutters for hopper	8 pcs	Set
117	9702310	V-belt	6 pcs	Set
122	901407	Crusher ring		Pce
123	901408	Segment		Pce
124	970526	Cylinder		Pce
127	941445	Key		Pce
133	901402	Lower hopper		Pce

## Drawing – spare parts

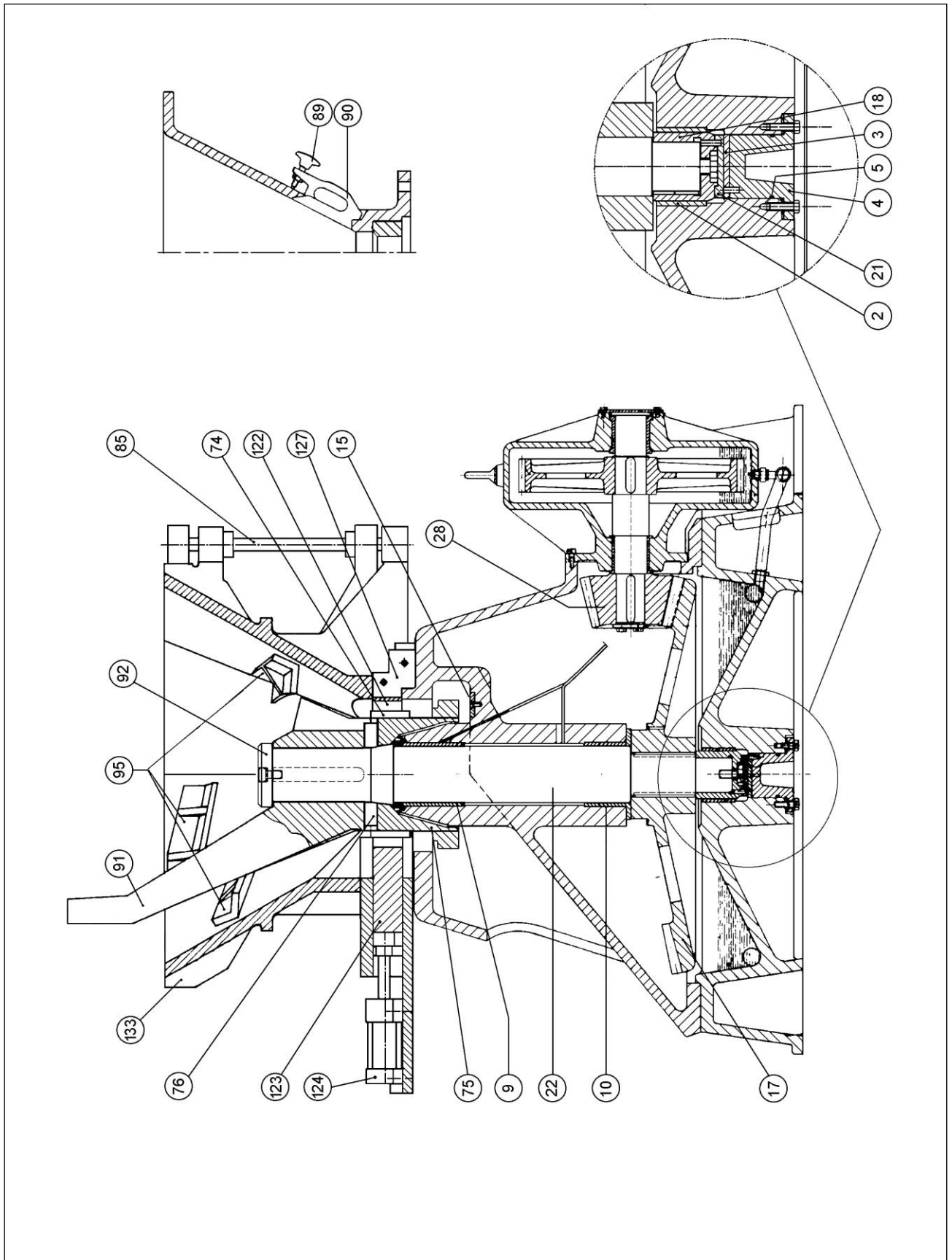



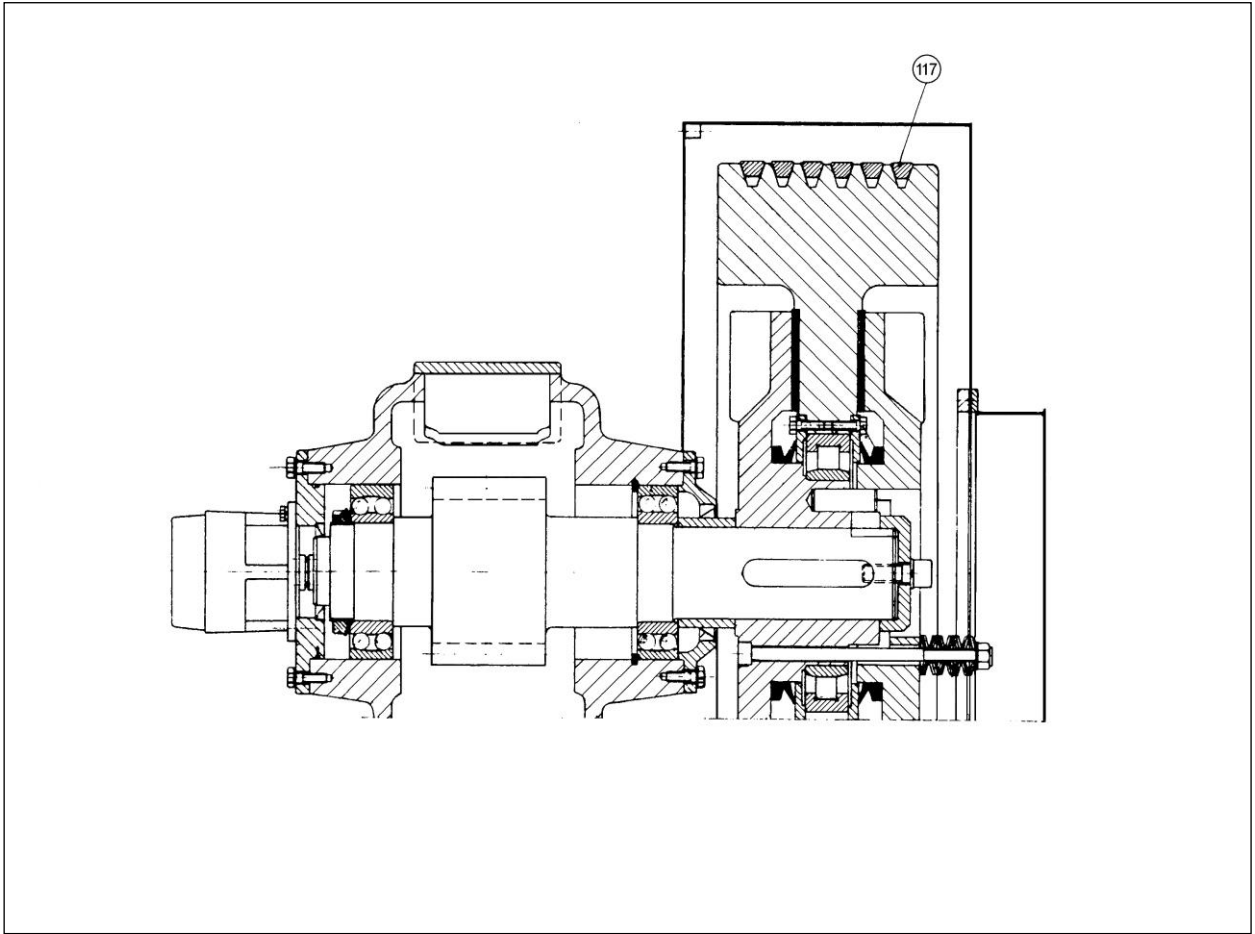

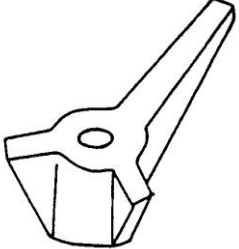
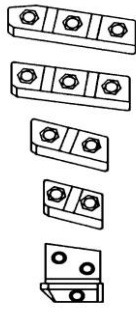
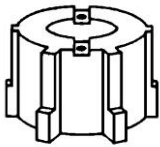
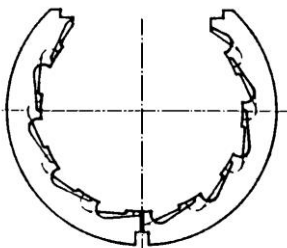

**Drawing – spare parts**

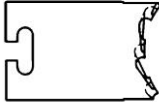
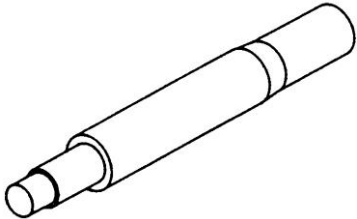

## Spare parts that should be stocked

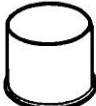
Pos	Article No.	Designation	Qty	
91	901405	Feeder arm	1 pce	
95	901424 921128 921127 921124 921123 921129	Cutters for hopper	8 pcs 2 pcs 1 pce 2 pcs 2 pcs 1 pce	
75 75	901415 901406	Coarse crusher head Fine crusher head	1 pce 1 pce	
122	901407	Crusher ring	1 pce	

## Spare parts that should be stocked

Pos	Article No.	Denomination	Qty	
123	901408	Segment	1 pce	
22	941404	Shaft	1 pce	
9	941405	Bushing	1 pce	
10	941415	Bushing	1 pce	
2	941406	Bushing	1 pce	
21	981408	Wearing plate	1 pce	
3	981407	Wearing plate	1 pce	

## Trouble-shooting

This trouble-shooting schedule only serves as a guide to probable reasons for faults. As mentioned earlier correct maintenance is the best insurance against the development of defects.

Problem	Symptom	Action
The crusher does not start.	<p>The doors are not closed.</p> <p>Electrical fault.</p> <p>The segment (pos. 123) is not in the right position (see indicator lamp).</p>	<p>Check the doors.</p> <p>Check the fuses.</p> <p>Check what has blocked the segment and remove.</p>
The motor starts but the feeder arm stands still.	Incorrect set slip clutch or poorly tightened V-belts.	Set the slip clutch as per this manual or tighten the V-belts with the belt adjuster on the motor bracket.
The motor reverses several times until the protective motor switch shuts off.	Large pieces have fallen down in the hopper and blocked the feeder arm.	<p>Remove the pieces.</p> <p><b>NB!</b> Cut the main power before working in the hopper.</p>
Poor crushing effect, i.e. long swarf in the output.	Worn down crushing tools (crusher head, crusher ring), wrong type of crushing tools regarding the type of swarf. The crusher hopper is not filled enough.	<p>Exchange the crushing tools. Always allow the hopper to be filled.</p> <p><b>NB!</b> The crusher works best when the hopper is filled.</p>
The bearing on the shaft overheats.	Bad greasing.	Look in this manual for greasing instructions.

Examples of erection

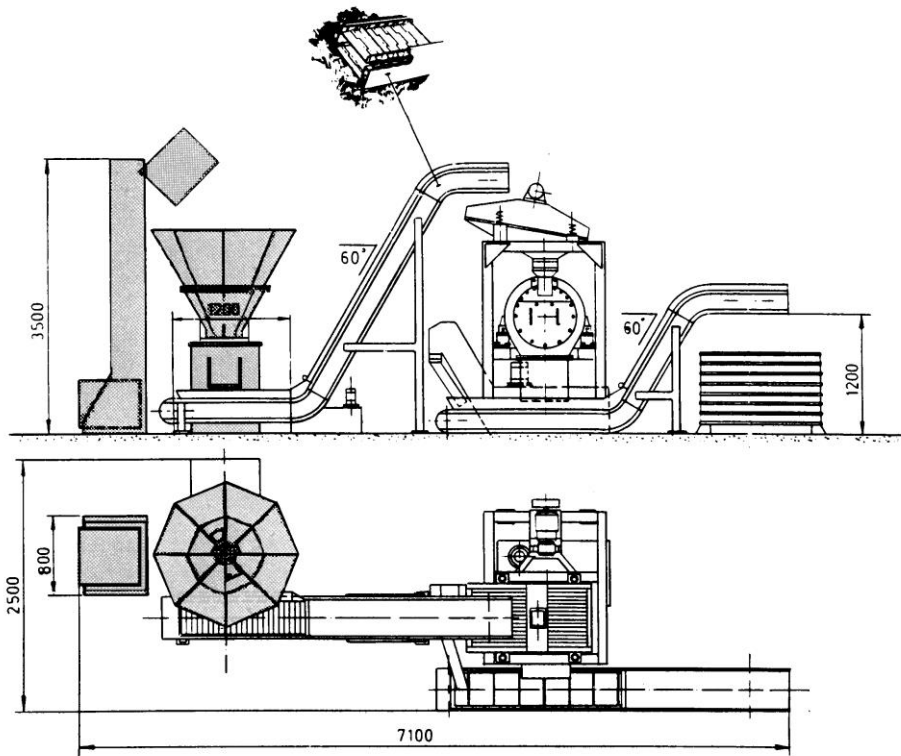

*Skiphoist feeding*

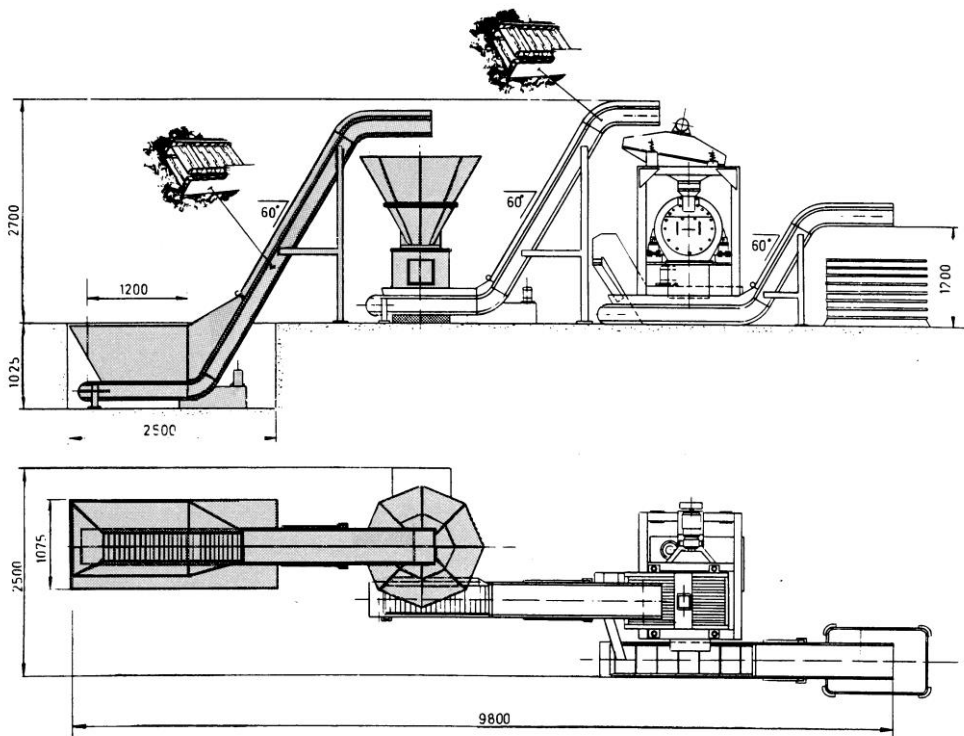

*Conveyor feeding*