

ARBOGA - DARENTH

OPERATING INSTRUCTIONS

SWARF CRUSHER

TYPE KB20

Customer:

Order No.:

Manufacturing No.:

Delivery date:

ARBOGA-DARENTH AB

Box 1022, SE-732 27 ARBOGA, Sweden, Tel +46 589 - 610200, Fax +46 589 - 610210
E-mail: info@arbogadarenth.se

Contents

Foreword	2
Garantee	3
Safety regulations	4
Swarf crusher KB20 – figure 1	5
Operation - figure 2	6
Lifting instruction - figure 3	7
Installation - figure 4.....	8
Assembly instructions	9
Slip clutch	10
Automatic bar end rejector.....	10
Greasing	11
Hydraulic system.....	11
Hydraulic diagram for pneumatic pump	12
Hydraulic diagram for electric pump	13
Spare parts	14-15
Drawing with pos.nos.	16-17
Spare parts – definitely to be stocked	18
Spare parts – preferably to be stocked.....	19
Trouble-shooting	20
Examples of erection.....	21

Enclosure

Foreword

ARBOGA-DARENTH Swarf Crushers guarantee good design, quality components and skilled labour plus years of experience in swarf handling and swarf crushing. All these abilities have been used to design a product with high reliability and long service life. We are convinced that your experiences will confirm your choice of ARBOGA-DARENTH Swarf Crusher.

Length of life and reliability can, as with any machine tool, be prolonged with correct installation and correct maintenance. It pays off to follow our advice for maintenance.

This maintenance manual consists of instructions and spare parts list for your new ARBOGA-DARENTH Swarf Crusher. It also contains greasing instructions, exploded view and a simple schedule for trouble-shooting.

ARBOGA-DARENTH Swarf Crushers are normally used in swarf handling systems which we design, sell and install.

All Swarf Crushers which leave our works are checked and do not need any additional maintenance other than stated in this manual.

For orders of spare parts and if you want to contact our engineers please find our phone number and address at the front page of this instruction.

Guarantee

All products from ARBOGA-DARENTH are guaranteed free from any fault in material and labour during a period of one year. One year consists of 365 calendar days or 1800 hours which ever occurs first. The guarantee period for our products starts the day the equipment is sent to the client and continues during one year as earlier described. This is due if our maintenance and control recommendations are followed.

The guarantee is not valid for incorrect erection, misuse, incorrect maintenance or if maintenance is not made due to our recommendations and accepted industry practice.

During the guarantee period and after written notice to us, we guarantee that all parts manufactured in our plant which are faulty regarding material or labour shall be replaced. We give no further guarantee either written or verbal for costs except material and man labour.

This guarantee or other guarantees from us do not cover:

1. Damage after the guarantee period is ended.
2. Damage caused by chemical reactions or wear due to the detail has been submitted to external influences.
3. Equipment damaged at delivery or by accidents.
4. Damage through misuse, incorrect use or feeding of the Crusher or if recommended maintenance is not followed.
5. Damage to equipment which have been repaired or changed by others than by the one who has been acknowledged as our sole representative.
6. Wear parts.

The capacity depends on volume/weight of material, size and shape of the chips. The capacity and residual humidity data specified in our order confirmation are valid for your crusher.

Safety regulations

- Electrical installations have to be done by qualified personnel only.
- At connection of voltage feed as well as at service and maintenance work on the crusher the circuit breaker must be off.
- Test the emergency stop at installation and always when maintenance and service have been done.
- The crusher must not be operated with the covers removed.
- Protective goggles must be used for work around the crusher.
- Materials able to crush are aluminium, brass, nimonic, stellite and all types of steel swarf, if any other material please ask Arboga-Darenth.
- The data sheet from the coolant supplier must be studied as parts from coolant can cause allergic reactions.

WARNING!

The floor around the crusher might get slippery from coolant getting outside the machine.

Swarf crusher KB20

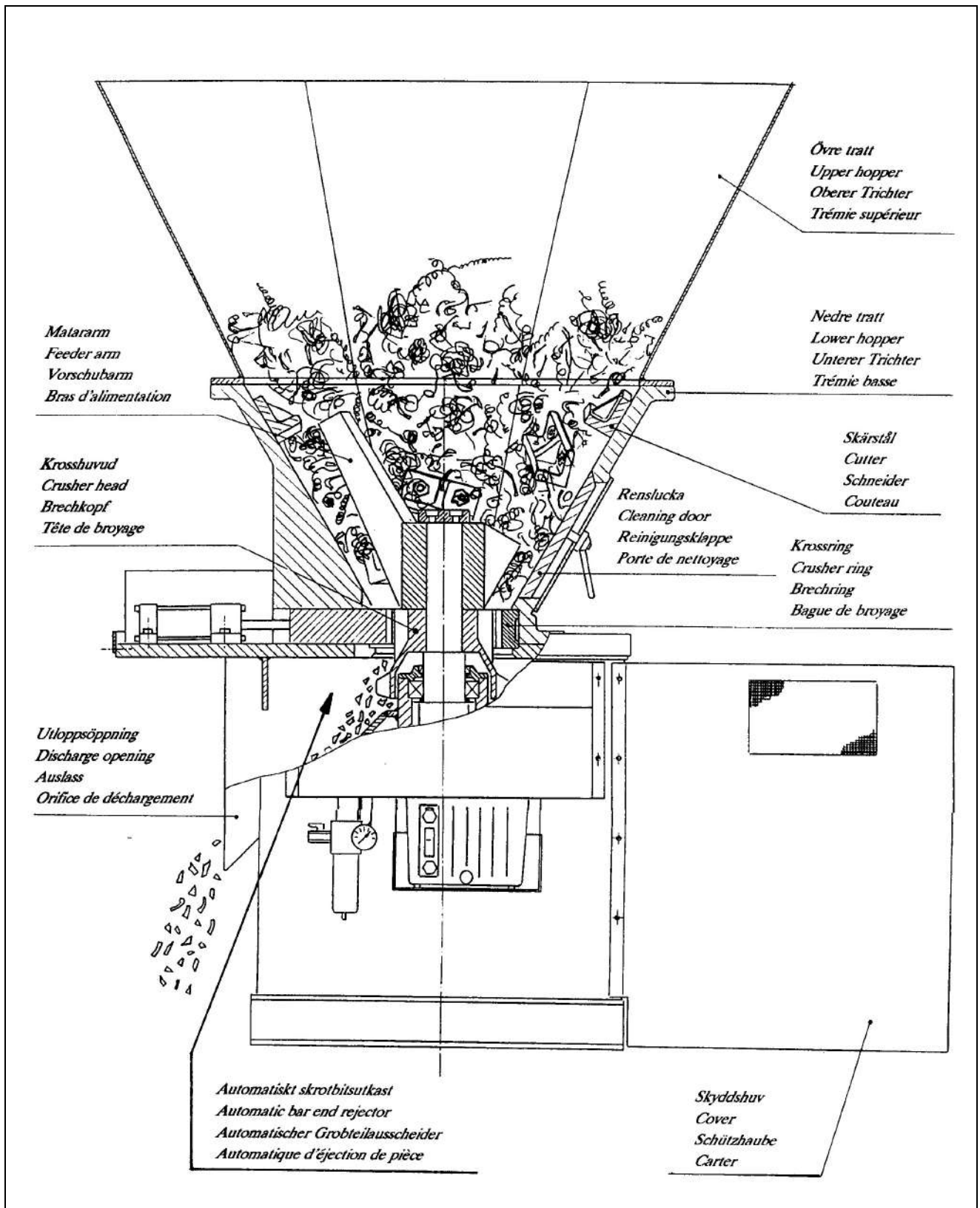

Figure 1

Working method

The swarf is fed into the hopper (a) to the upper part of the crusher. On the sides of the conical hopper are bolted angled cutters (b). On top of the revolving shaft there is a feeding arm (c) with hard-welded cutters. On the shaft there is a rotating crusher head (d) and an outer stationary crusher ring (e). The swarf is broken up in short pieces. The swarf is fed successively down through the crusher chamber, where the fine crushing takes place in the lower part. After completed crushing the swarf is discharged through a chute in the frame. It is important that the hopper always is well filled up, otherwise it can happen that long swarf can go through the crushing tools. To prevent solid parts getting jammed in the crusher it is equipped with bar end rejector (f).

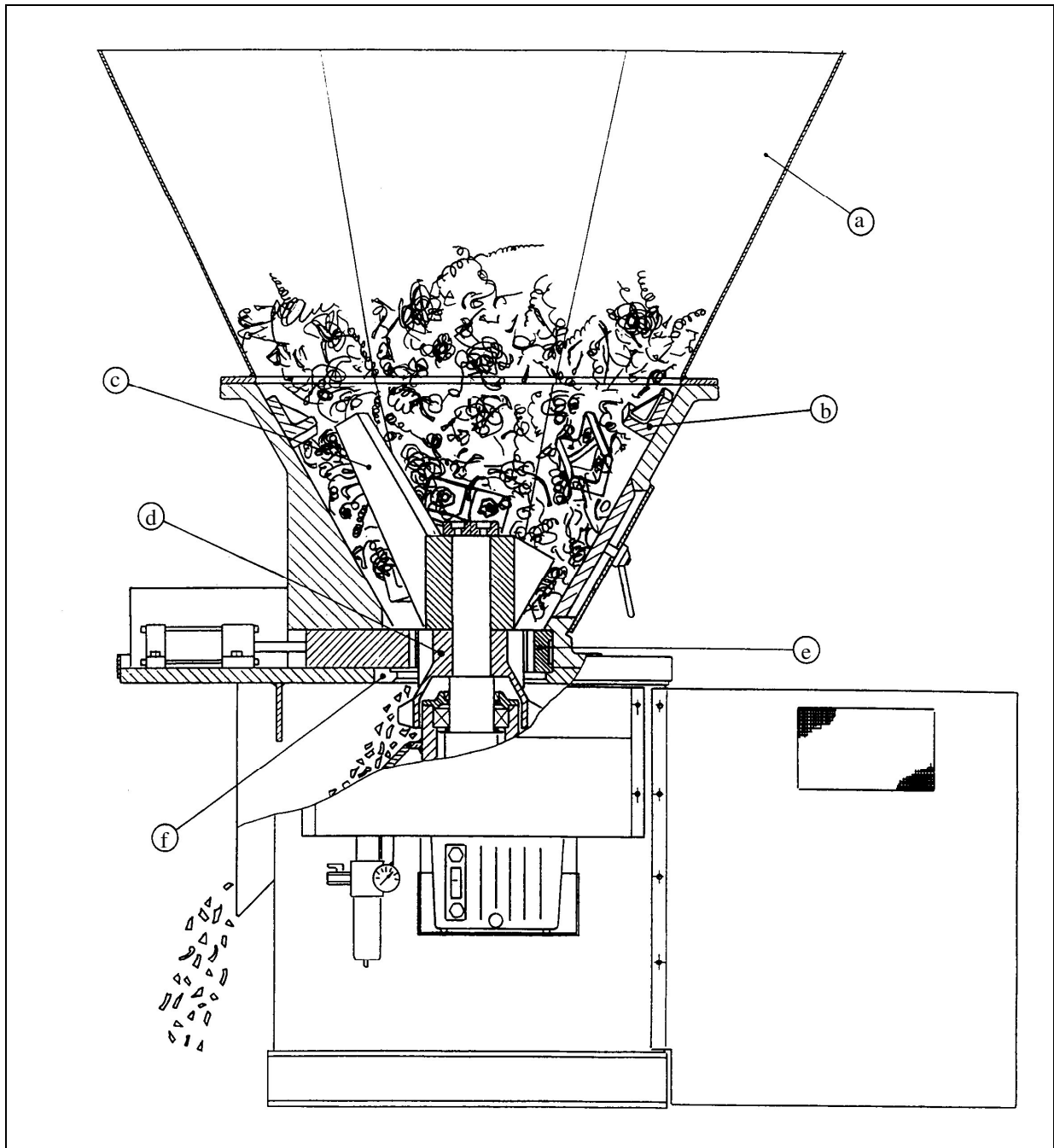

Figure 2

Lifting instruction

Lift the crusher by crane. Remove the upper hopper and place eye bolts (M12) in the lower hopper.

Fix the crusher with anchor bolts M20.

Weight 1200 kg

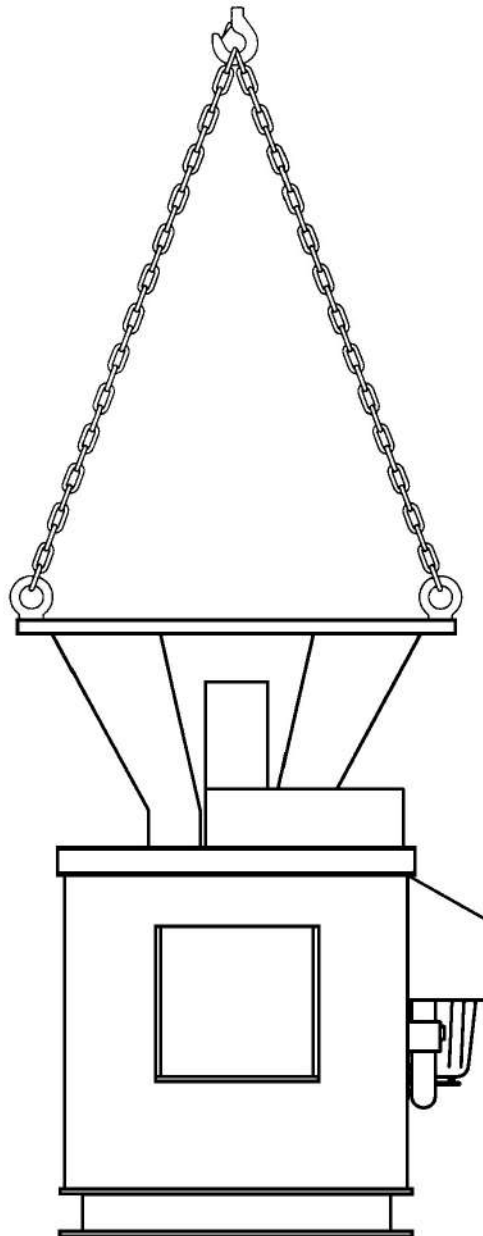

Figure 3

Installation

Figure 4 shows the main dimensions of the crusher. No specific foundations are required. The crusher must however be bolted down.

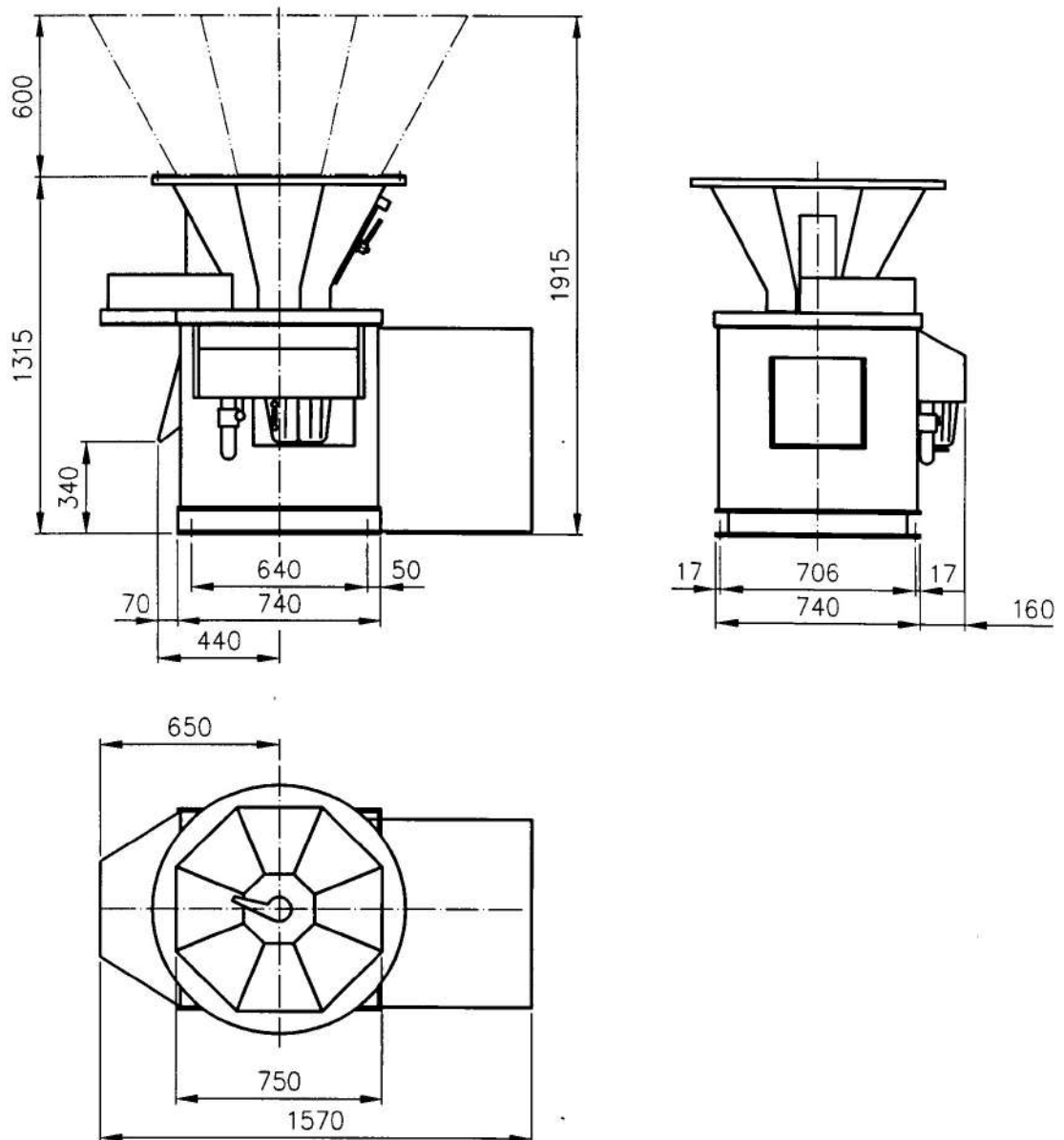

Figure 4

Assembly instructions

Cutter

1. Turn off the circuit breaker.
2. Remove the upper hopper.
3. Unscrew one cutter from the outside of the hopper.
4. Re-assemble the corresponding new cutter.
5. Turn the crusher arm around so that the other cutters are free.
6. Remove the other cutters and replace them with new.
7. Be careful to re-assemble the corresponding cutter in its correct place.
(See page 18 Pos 6, 7, 8 and 2)
8. Turn the crusher arm around and check that it is clear from the cutters, 1-2 mm is a suitable distance between crusher arm and cutters.
9. Re-assemble the upper hopper.
10. Turn on the circuit breaker.

Crusher arm

1. Turn off the circuit breaker.
2. Remove the upper hopper.
3. Disassemble the washer on the shaft holding the crusher arm.
4. Place 2 eye bolts (M16) in the crusher arm.
5. Lift the crusher arm.
6. Place the new crusher arm on the shaft, when changing to a new arm, clean the hole.
7. Re-assemble the washer.
8. Re-assemble the upper hopper.
9. Turn on the circuit breaker.

Crusher ring and crusher head

1. Turn off the circuit breaker.
2. Remove the upper hopper.
3. Disassemble the washer on the shaft holding the crusher arm.
4. Place 2 eye bolts (M16) in the crusher arm.
5. Lift the crusher arm.
6. Remove the lower hopper.
7. Lift the crusher ring.
8. Remove the segment from the bar end rejector.
9. Lift the crusher head.
10. Place the new crusher head with a new packing on the shaft.
11. Assemble the new segment in the bar end rejector.
12. Place the new crusher ring in the groove.
13. Secure the crusher ring with the key.
14. Check that the crusher head revolves, if not grind it.
15. Re-assemble the lower crusher hopper and tighten with silicone packing.
16. Put the keys in the shaft and the crusher head.
17. Re-assemble the crusher arm, when changing to a new arm, clean the hole.
18. Re-assemble the upper hopper.
19. Turn on the circuit breaker.

Slip clutch

The slip clutch on the pulley of the gear is to eliminate the risks of damage to the crusher if exceptional high peak loads occur, i.e. objects that cannot be crushed entering the hopper together with the swarf.

Slip clutch setting

On delivery the clutch is set to slip at a certain current. Normal wear of the discs makes the slip clutch slip at a lower rate than the original setting. When this occurs it is necessary to adjust the slip clutch. This is done by tightening the disc spring on the hub.

CAUTION!

Before any work on the crusher and the clutch, the main switch must be switched off so that the crusher cannot be started.

The adjustment will be done as follow:

1. Turn the time relay to 0.
2. Block the feeder arm in the hopper.
3. Tighten the clutch by releasing the securing plate and tighten the big nut (pos. 25).
NB! The slip clutch must not be tightened too hard.
4. Check that the current is max 2 x normal current.
5. Remove the blockage of the feeder arm in the hopper.
6. Put the time relay back to normal position, i.e. 1 second.

Automatic bar end rejector

If the crusher is overloaded, i.e. if solid parts are jammed in the lower tools, the electronic torque limiter switches off the motor. A hydraulic cylinder pulls one segment of the crusher ring back and the crusher reverses for about 3 secs. Solid parts and swarf can then pass through the crushing tools. After reversing the crusher starts automatically. If an uncrushable solid part drops down into the hopper, the reversing action is repeated until the protective motor switch shuts off. The object that has stopped the crusher should be removed before the protective motor switch is put back into operation.

CAUTION!

Before examination, the main switch must be turned off and locked so that the crusher can not start involuntarily while you are working with it. The electronic torque limiter has two (2) time delays, one for start 0.1–20 sec. (allows start with overload) and one for reaction time to avoid reversing with short peak loads.

Greasing

1. Crusher shaft bearings

Greasing is to be done through 2 nipples. These are situated on the frame. Use ball bearing grease of good quality (eg Statoil Uniway LI62 or similar).

Greasing interval: every 6th month at 1-shift operation, 40-50 g grease per bearing.

2. Bar end rejector

Greasing of the bar end rejector is to be done through 2 nipples. These are situated on the crusher hopper, one on each side of the bar end rejector, see page 16.

Greasing interval: every 14th day at 1-shift operation, 20 g grease per nipple.

3. Gear

The gear manufacturer's specifications are to be followed, see enclosure.

Hydraulic system

To run the bar end rejector the crusher is equipped with a pneumatic hydraulic unit. The filter-regulator (pos 55) should be set to 4 bar. The unit gives an increase in pressure of 25 times, i.e the working pressure is 100 bar. To protect the equipment from pressure impulses which can occur when the crusher tools are exposed to strong blows, the unit is equipped with an overflow valve (pos 57). This should be set for 125 bar. Adjust the overflow valve as follows:

1. Loosen the locking nut on the overflow valve and screw down the adjusting screw completely.
2. Connect air to the ball valve (pos 54)
3. Adjust the air pressure to 5 bar (corresponding 125 bar oil pressurer).
4. Screw the adjustment screw slowly back until the unit starts to pump regularly through the overflow valve (the pump can do some single strokes before the right position occurs).
5. Hold the adjustment screw and tighten the locking nut.
6. Once again adjust the air pressure to 4 bar.

Maintenance

The water separator of the filter-regulator (pos 55) is equipped with semi-automatic drainage, i.e when the air pressure is off, separated water is drained. If air pressure is always connected, turn off the air to the crusher with the ball valve (pos 54) in order to let the water out. Check the oil level in the hydraulic unit once a month. When filling, use hydraulic oil of good quality.

Hydraulic diagram for pneumatic pump

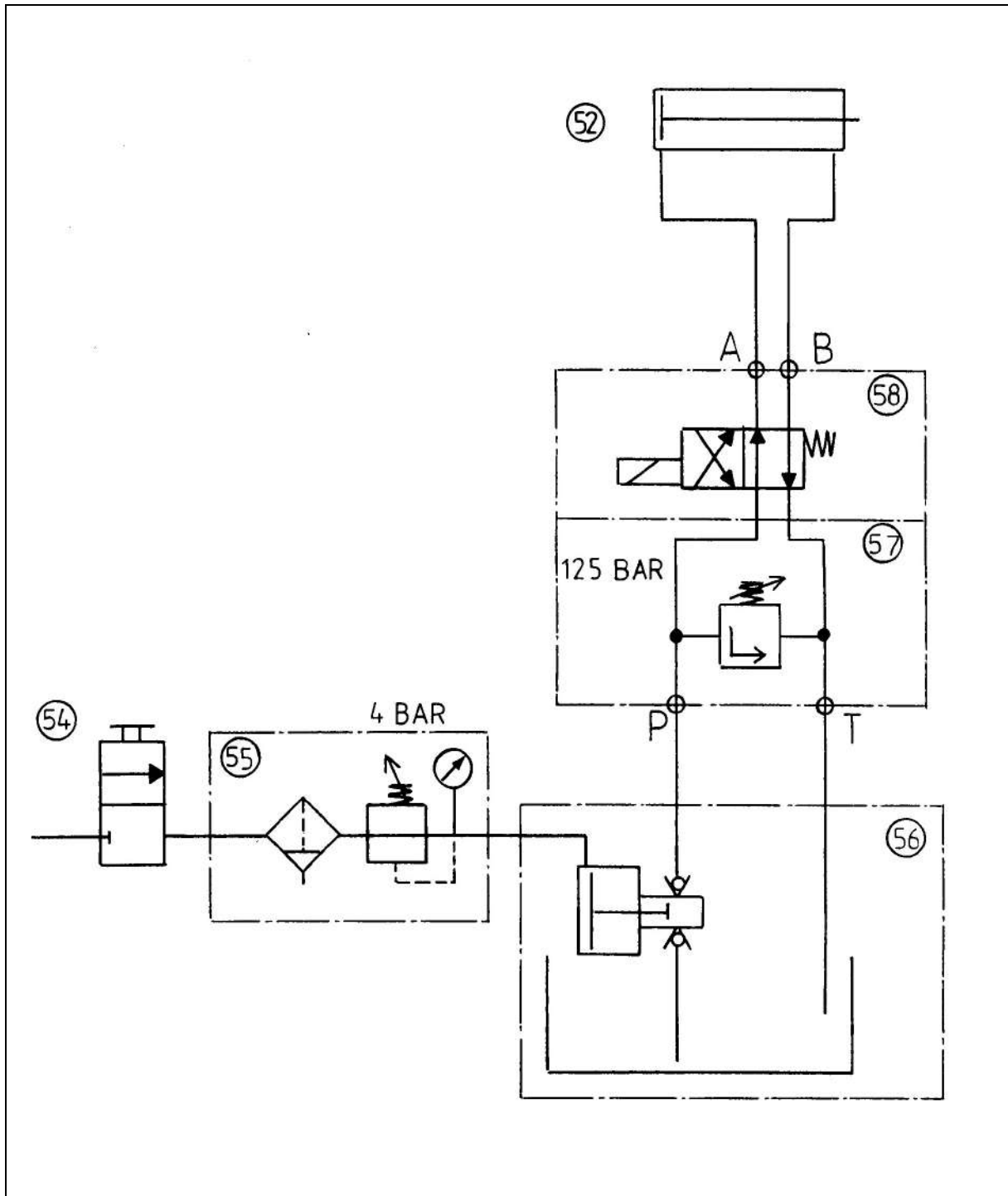

Hydraulic diagram for electric pump

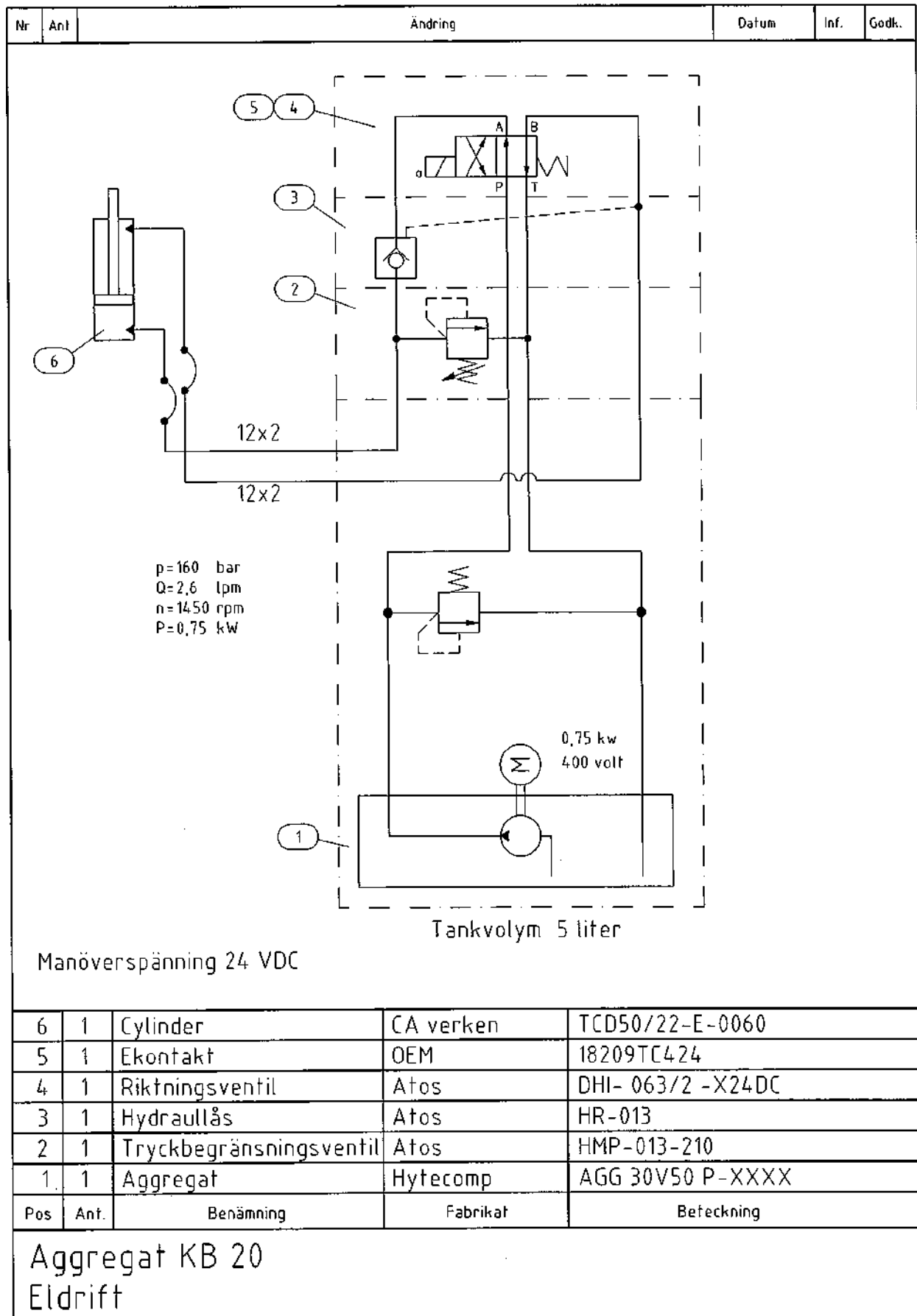

Spare parts list

NB! When ordering spare parts, please specify the following data:

- Type
- Designation
- Serial number
- Article number

Pos	Article No.	Designation	Qty	Unit
1	901201	Upper hopper		Pce
2	921109	Cutter IV	2 pcs	Set
3	901207	Feeder arm		Pce
4	941101	Spacer (incl 2 stop screws)		Pce
	97031011640	Screw	2 pcs	Set
5	901222	Cutter set	8 pcs	Set
6	921106	Cutter I	2 pcs	Set
7	921107	Cutter II	2 pcs	Set
8	921108	Cutter III	2 pcs	Set
9	901223	Locking device, complete		Pce
10	901202	Lower hopper		Pce
11	9703820215	Key		Pce
12	901216	Cleaning door, complete		Pce
13	941102	Key	2 pcs	Set
14	901205	Fine crusher head		Pce
15	901220	Coarse crusher head		Pce
16	901206	Crusher ring		Pce
17	901208	Motor bracket		Pce
18	96103	Motor, 11 kW		Pce
19	901213	Cover		Pce
20	9702403	Pulley		Pce
21	9702303	V-belt	3 pcs	Set
22	901209	Hub		Pce
23	970107	Bearing		Pce
24	901210	Pressure plate		Pce
25	970117	Shaft nut		Pce
26	970111	Lock washer		Pce
27	921210	Spacer		Pce
	97031010830	Screw		Set
28	971001	Disc spring	3 pcs	Set
29	970371020	Pin	2 pcs	Set
30	941113	Disc	2 pcs	Set
31	941112	Pulley		Pce
32	941214	Spacer		Pce
	97031011040	Screw	4 pcs	Set
33	9703818170	Key		Pce
34	96402	Gear unit		Pce

Spare parts list (cont.)

Pos	Article No.	Designation	Qty	Unit
35	970704	Packing		Pce
36	941109	Bearing cover		Pce
37	970110	Shaft nut		Pce
38	970109	Lock washer		Pce
39	970106	Bearing	2 pcs	Set
40	901204	Shaft		Pce
41	910103	Cover plate		Pce
42	941110	Ring		Pce
43	970116	Bearing		Pce
44	941108	Bearing cover		Pce
45	970703	Bearing		Pce
46	901203	Frame		Pce
47	901215	Segment		Pce
48	95208	Limit switch		Pce
49	970511	Hydraulic tube (315 mm)		Pce
50	970510	Hydraulic tube (415 mm)		Pce
51	901217	Cover cylinder		Pce
52	970502	Hydraulic cylinder		Pce
53	95208	Level indicator		Pce
54	970517	Ball valve		Pce
55	970518	Filter-regulator		Pce
56	970501	Hydraulic unit		Pce
57	970519	Overflow valve		Pce
58	970520	Hydraulic valve		Pce
59	970509	Hydraulic tube (585 mm)	2 pcs	Set
60	901218	Cover hydraulic unit		Pce
61	95214	Magnetic switch		Pce

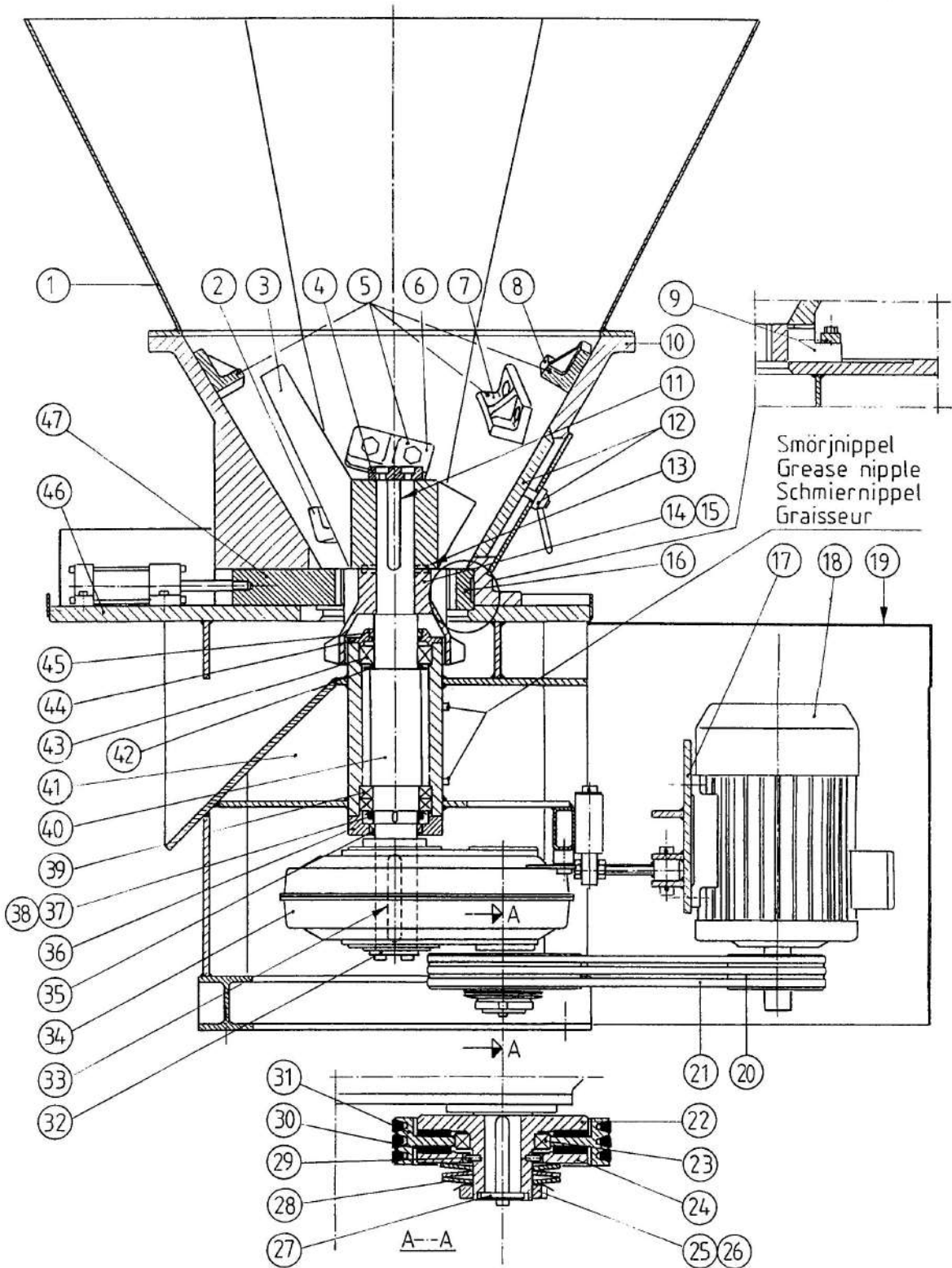

Drawing – spare parts

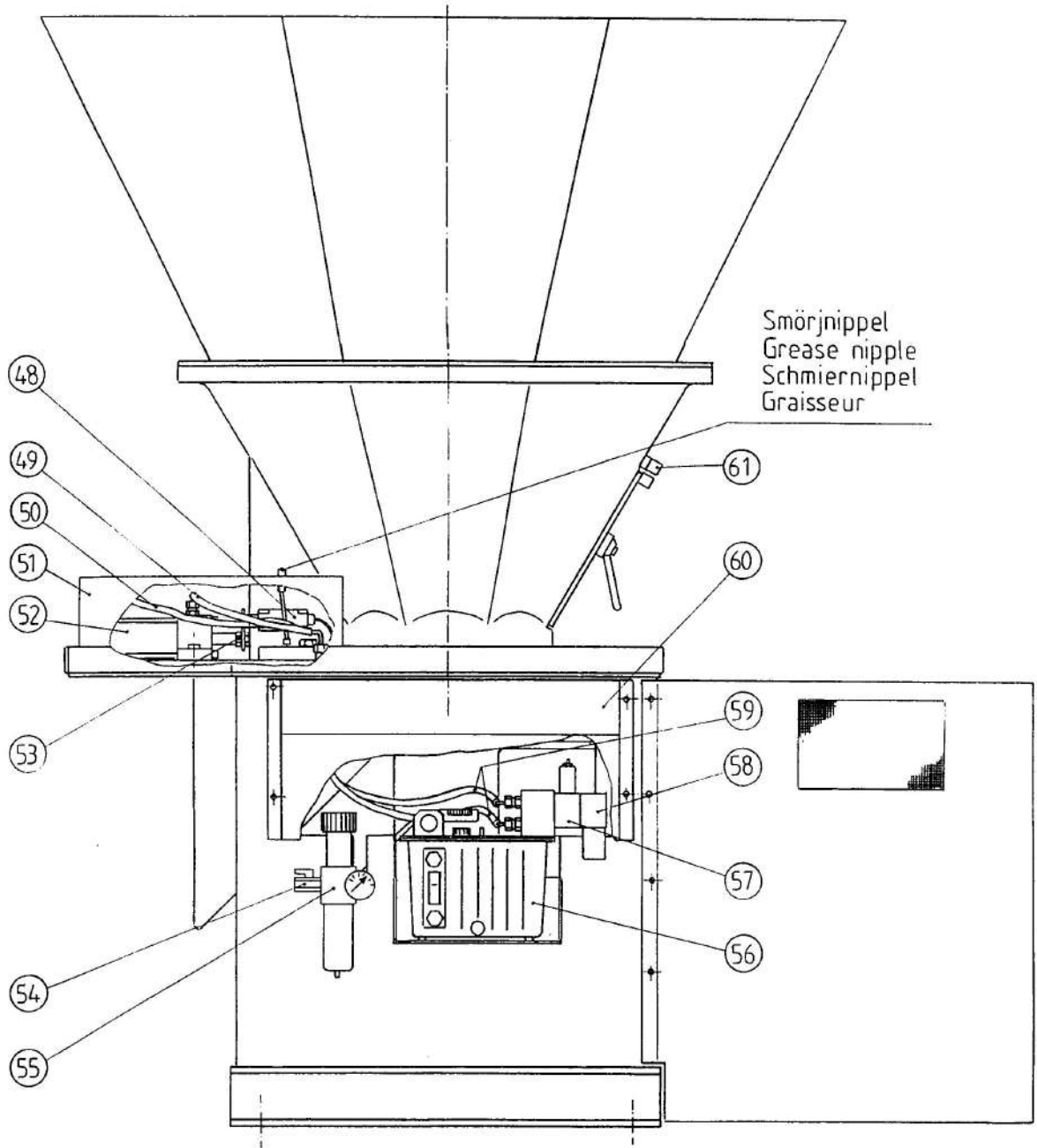

Drawing – spare parts

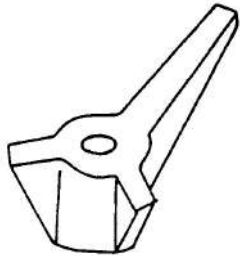

Spare parts that should definitely be stocked

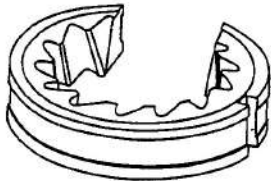
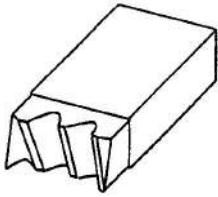
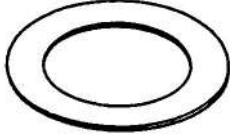
Pos	Article No.	Designation	Qty	
3	901207	Feeder arm	1 pce	
14	901205	Fine crusher head (8 cutting edges)	1 pce	
15	901220	Coarse crusher head (4 cutting edges)	1 pce	
16	901206	Crusher ring	1 pce	
47	901215	Segment	1 pce	
30	941113	Disc	2 pcs	

Spare parts that should preferably be stocked

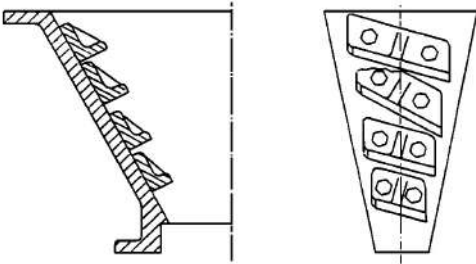
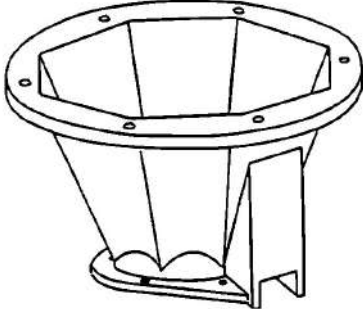
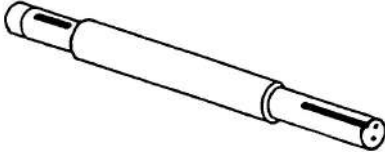
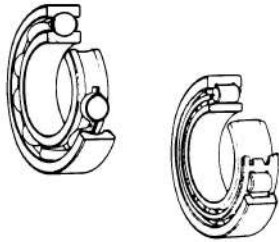
Pos	Article No.	Designation	Qty	
8	921108	Cutter III	2 pcs	
7	921107	Cutter II	2 pcs	
6	921106	Cutter I	2 pcs	
2	921109	Cutter IV	2 pce	
10	901202	Lower hopper	1 pce	
40	901204	Shaft	1 pce	
39 43	970106 970116	Bearing Bearing	2 pcs 1 pce	
35 45	970704 970703	Packing Packing	1 pce 1 pce	

Trouble-shooting

This trouble-shooting schedule only serves as a guide to probable reasons for faults. As mentioned earlier correct maintenance is the best insurance against the development of defects.

Problem	Symptom	Action
The crusher does not start.	Electrical fault. The segment (pos 47) is not in the right position (see indicator lamp).	Check the fuses and torque limiters. Check what has blocked the segment and remove.
The motor starts but the feeder arm stands still.	Incorrect set slip clutch or poorly tightened V-belts.	Set the slip clutch as per this manual or tighten the V-belts with the belt adjuster on the motor bracket.
The motor reverses several times until the protective motor switch shuts off.	Large pieces have fallen down in the hopper and blocked the feeder arm.	Remove the pieces. NB! Cut the main power before working in the hopper. Restore the protective motor switch.
Poor crushing effect, i.e. long swarf in the output.	Worn down crushing tools (crusher head, crusher ring), wrong type of crushing tools regarding the type of swarf. The crusher hopper is not filled enough.	Exchange the crushing tools. Always allow the hopper to be filled. NB! The crusher works best when the hopper is filled.
The bearing on the shaft overheats.	Bad greasing.	Look in this manual for greasing instructions.

Exemples of erection

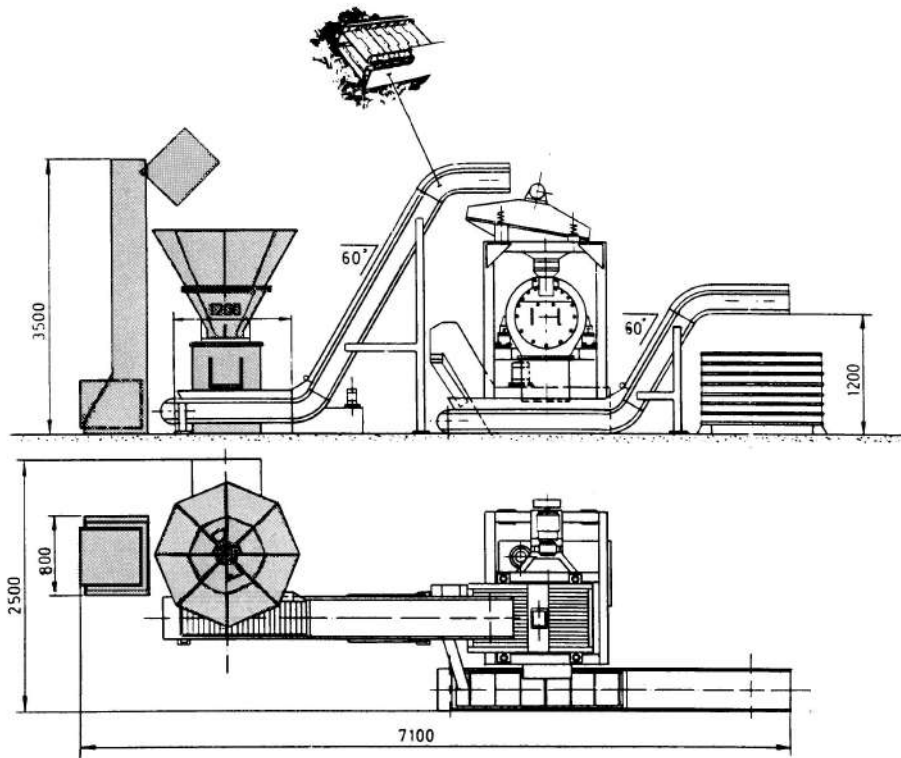

Skiphoist feeding

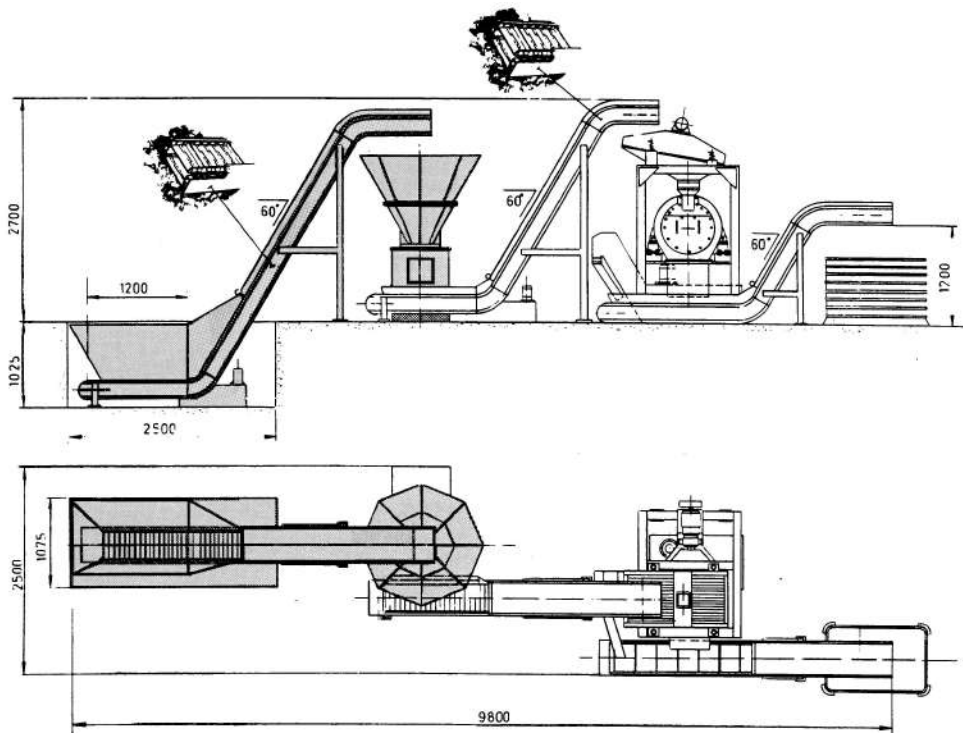

Conveyor feeding