

ARBOGA - DARENTH

OPERATING INSTRUCTIONS FOR HORIZONTAL SWARF CENTRIFUGE TYPE HD50

Customer:.....

Order No.:.....

Manufacturing No.:.....

Delivery date:.....

ARBOGA-DARENTH AB

Box 1022, S-732 27 ARBOGA, Sweden, Tel +46 589 - 12720, Fax +46 589 - 16960
E-mail: info@arbogadarenth.se

Contents

Foreword	2
Guarantee	3
Safety regulations	4
Operation	5
Material flow in centrifuge - figure 1	6
Lifting instruction – figure 2.....	7
Installation	8
Installation drawing - figure 3	9
Handling	10
Maintenance	11
Lubrication instructions	11
Trouble-shooting	12
Spare parts list	13
Drawing with pos.no	14

Foreword

ARBOGA-DARENTH Swarf Centrifuges guarantee good design, quality components and skilled labour plus years of experience in swarf handling and swarf crushing. All these abilities have been used to design a product with high reliability and long service life. We are convinced that your experiences will confirm your choice of ARBOGA-DARENTH Swarf Centrifuge.

Length of life and reliability can, as with any machine tool, be prolonged with correct installation and correct maintenance. It pays off to follow our advice for maintenance.

This maintenance manual consists of instructions and spare parts list for your new ARBOGA-DARENTH Swarf Centrifuge. It also contains greasing instructions, exploded view and a simple schedule for trouble-shooting.

ARBOGA-DARENTH Swarf Centrifuges are normally used in swarf handling systems which we design, sell and install.

All Swarf Centrifuges which leave our works are checked and do not need any additional maintenance other than stated in this manual.

For orders of spare parts and if you want to contact our engineers please find our phone number and address at the front page of this instruction.

Guarantee

All products from ARBOGA-DARENTH are guaranteed free from any fault in material and labour during a period of one year. One year consists of 365 calendar days or 1800 hours whichever ever occurs first. The guarantee period for our products starts the day the equipment is sent to the client and continues during one year as earlier described. This is due if our maintenance and control recommendations are followed.

The guarantee is not valid for incorrect erection, misuse, incorrect maintenance or if maintenance is not made due to our recommendations and accepted industry practice.

During the guarantee period and after written notice to us, we guarantee that all parts manufactured in our plant which are faulty regarding material or labour shall be replaced. We give no further guarantee either written or verbal for costs except material and man labour.

This guarantee or other guarantees from us do not cover:

1. Damage after the guarantee period is ended.
2. Damage caused by chemical reactions or wear due to the detail has been submitted to external influences.
3. Equipment damaged at delivery or by accidents.
4. Damage through misuse, incorrect use or feeding of the centrifuge or if recommended maintenance is not followed.
5. Damage to equipment which have been repaired or changed by others than by the one who has been acknowledged as our sole representative.
6. Wear parts.

The capacity depends on volume/weight of material, size and shape of the chips. The capacity and residual humidity data specified in our order confirmation are valid for your centrifuge.

Safety regulations

- Electrical installations have to be done by qualified personnel only.
- At connection of voltage feed as well as at service and maintenance work on the centrifuge the circuit breaker must be off.
- Test the emergency stop at installation and always when maintenance and service have been done.
- The centrifuge must not be operated with the covers removed.
- Materials able to centrifuge are different qualities of steel swarf as well as brass and cast iron swarf, if any other material please ask Arboga-Darenth.
- The data sheet from the coolant supplier must be studied as parts from coolant can cause allergic reactions.

WARNING!

The floor around the centrifuge might get slippery from coolant getting outside the machine.

Operation

The ARBOGA-DARENTH horizontal Swarf Centrifuge is a drum centrifuge, which via rotation movement exposes the supplied material to high G-forces. The solid particles are separated on the inner periphery of a drum lining, whilst the liquid passes through this.

Figure 1 shows the material flow through the centrifuge.

The material fed in through the top inlet hopper (1), glides down and is fed directly to the drum walls (6). On contact with the drum walls the material is accelerated to the speed of the drum at the periphery. During this acceleration phase the material moves outwards along the drum until it comes into contact with the wedge bar screen (3) or remaining layer of previously accelerated material. By building up an additional layer of material over the previous layer the old material is forced to glide over the screen and out from the centrifuge via the outlet for dry swarf (4). During the time the material is exposed to the centrifugal force the liquid is separated from the solid particles. When the material passes over the screen the liquid goes through this and out from the centrifuge via the outlet for liquids (7). This outlet is located immediately behind the outlet for dry swarf.

A conveyor should be connected to remove the solid particles. The liquid should be drained to a sedimentation tank, which in turn should be equipped with a drag conveyor.

Your ARBOGA-DARENTH Swarf Centrifuge is designed to operate at high rpm and is almost completely vibrationless. Each component in the rotating system is individually balanced so that all parts are fully replaceable without disturbing overall balance.

Despite the fact that the parts are individually balanced a certain imbalance may arise when material is fed in. To avoid vibrations being transferred to mountings the centrifuge is installed on vibration absorbers.

The screen opening is delivered as a standard 0.7 mm if not otherwise specified in the order. Other screen openings may be fitted.

Material flow in centrifuge

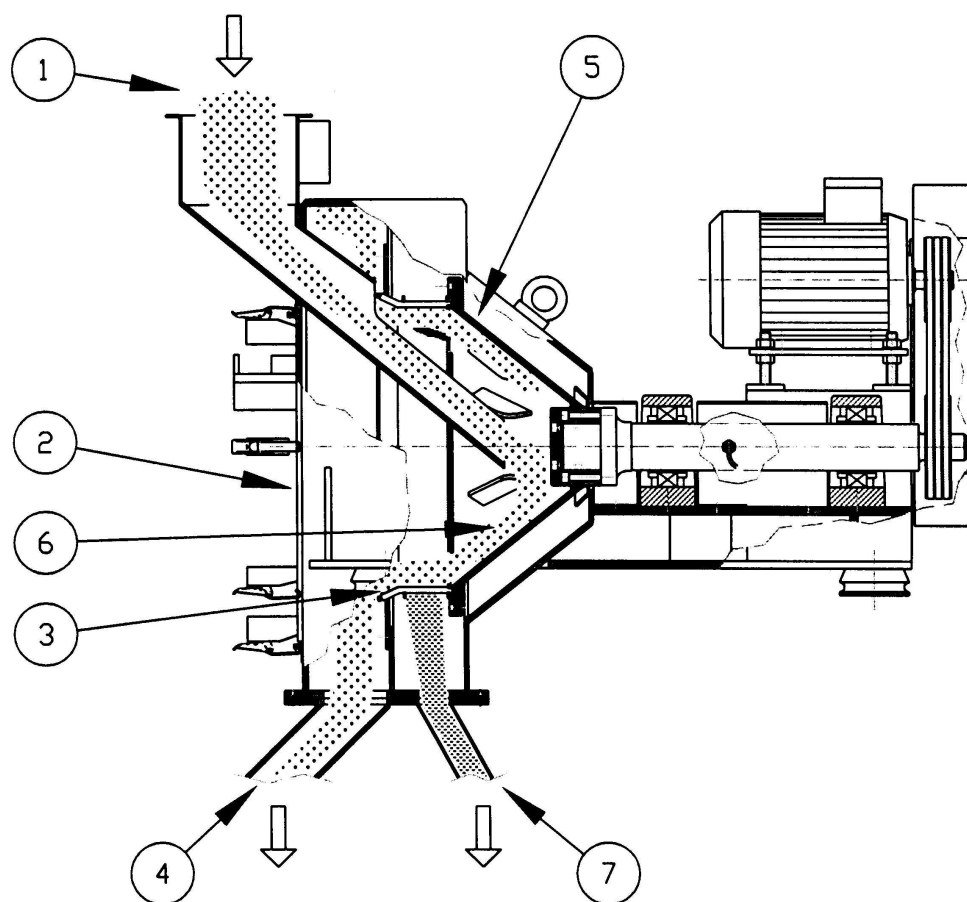

1. Inlet - wet chips
2. Access door
3. Self cleaning wedge bar screen
4. Outlet - wet chips
5. Separator bowl
6. Accelerator vanes
7. Liquid discharge

Figure 1

Lifting instruktion

Lift the centrifuge by crane. Use a chain of approved quality and strength and in adapted length. Place the chain in the eye bolt on the upper side of the centrifuge.

Weight 450 kg

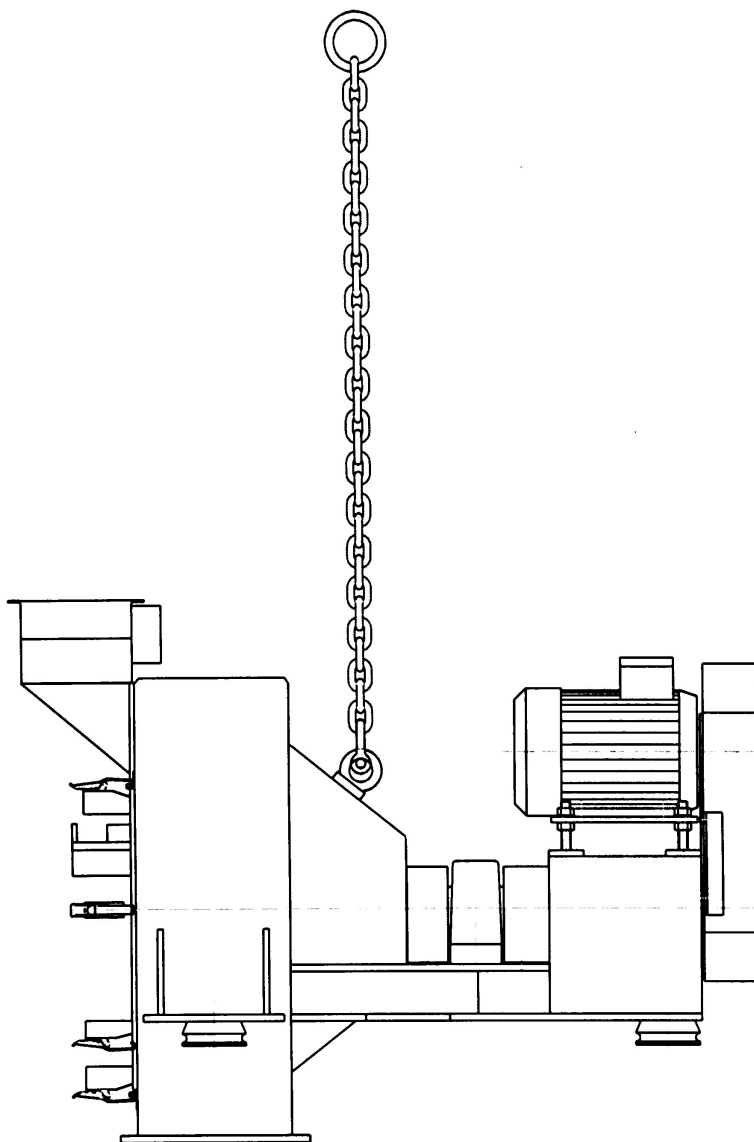

Figure 2

Installation

Consideration must be taken to the positioning of the centrifuge in relation to other equipment. The centrifuge requires very little space. However, space for maintenance must be available and adequate space must be ensured for access to all the hatches. There must be space in front of the machine for the replacement of screen, drum and the interior components.

ARBOGA-DARENTH Swarf Centrifuge is delivered fully fitted. Observe care during installation and always use the lifting hooks which it is equipped with. The mountings should be level and sufficiently secure to support a load of about 500 kg and also be available to sustain dynamic loads via the centrifuge's vibration absorber. The dynamic loading is normally very low.

There should be no rigid connections to the centrifuge. When the centrifuge is correctly installed it should be able to vibrate on the vibration absorbers without striking or causing any abrasion against any connection. Liquid and solid particles should be fed to a tank or conveyor. A fixed pipe connection should be avoided. The liquid outlet, however, must be shielded to prevent splash.

The motor is dimensioned as 4 kW, 380 V, 50 Hz and 3-phase. The electric cables to the motor must accommodate a certain flexibility.

Installation drawing

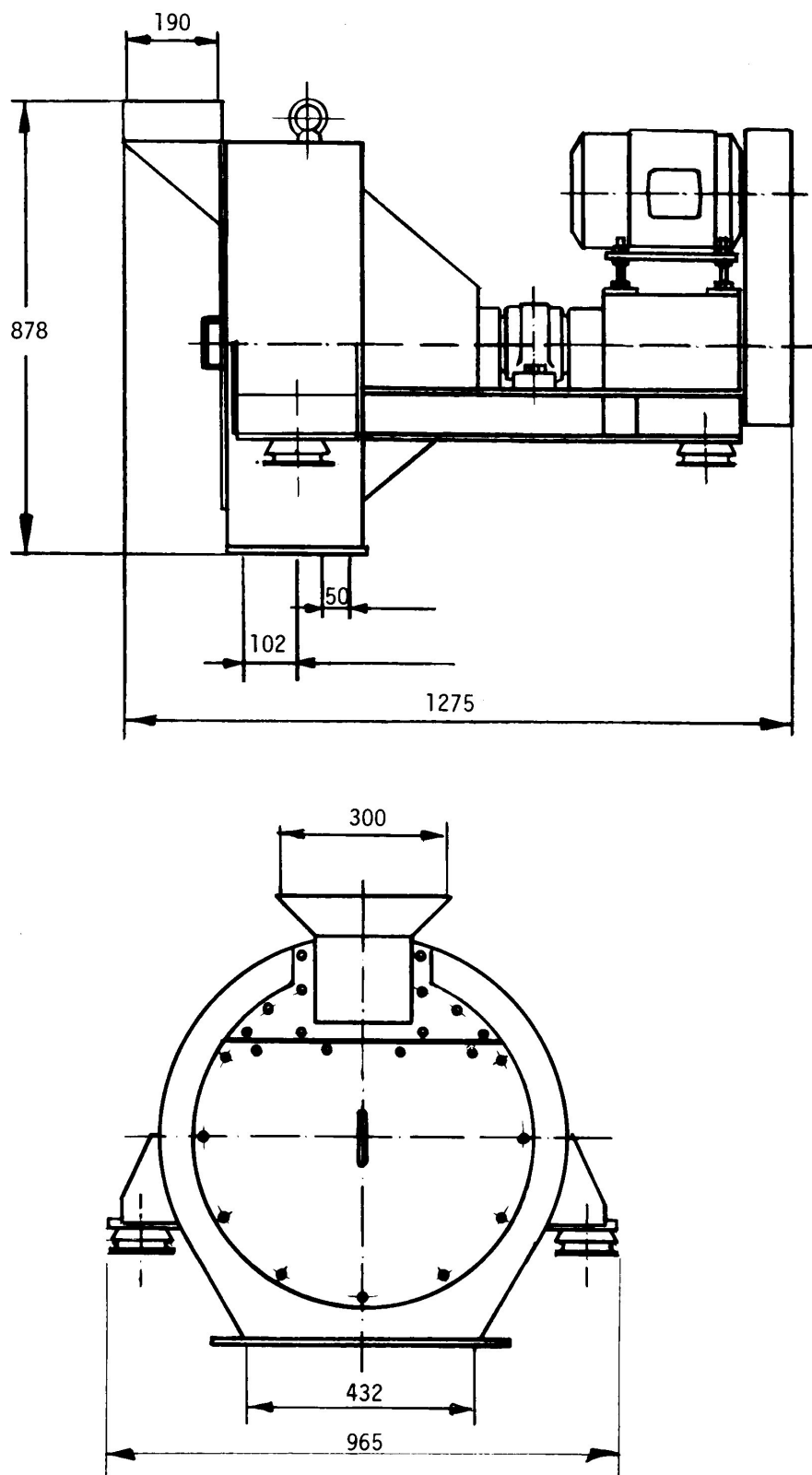

Figure 3

Handling

Study figure 1 on page 6 - Material flow in centrifuge - where a general description is provided.

Check the following points prior to putting into operation:

1. Free rotation
The drum should be able to be turned round by hand.
2. Motor loading
Check zero-load power and compare with power during loading and rating data of motor.
3. Observation of zero-load sound
Attention should be paid to the normal sound level of the equipment. **NOTE!** A screaming noise may be emitted by the V-belt when the drum is accelerating. This is normal.
4. Always start machine unloaded
If the machine is started when loaded then start load will exceed motor capacity. The centrifuge must not be fed until the correct speed of the drum has arised.
5. Feed the centrifuge evenly
Since the centrifuge works continuously it is of great importance that it is fed evenly to ensure a level of residual moisture in the centrifuged swarf as low as possible.

The operator should always be aware of the normal power consumption of the motor, normal outflow of solid particles, the liquid content of the material and the level of vibration, By considering the above mentioned factors and observing modifications one can be quite sure that the centrifuge will function properly.

Maintenance

ARBOGA-DARENTH Swarf Centrifuge is very robust in design but should like every other production machine be regularly checked and maintained. Daily checks should be made at the start of operations until a permanent maintenance schedule can be established. When this has been done only routine checks and general observations are necessary.

All parts coming into contact with the material which passes through the centrifuge are subject to wear. Negligent or delayed replacement of worn parts results in high repair costs and unsatisfactory separating of liquid. A maintenance schedule should therefore be established which also indicates when it is time to replace worn parts. This schedule may only be drawn up by you since wear is highly dependent upon the ingoing swarf quality. A basic rule, however, is to check the screen, drum and housing once a month in the case of 1-shift operations. Inspection takes place via the front hatch which is quickly removed.

Lubrication

The Swarf Centrifuge has grease lubricated bearings and temperature is normally high, which is why high quality grease should be used.

Lubrication intervals should be adjusted to current operating conditions, although should be at least every six months during 1-shift operations.

NOTE! Not more than 1/3 of the bearing housing.

Trouble-shooting

This trouble-shooting schedule only serves as a guide to probable reasons for faults. As mentioned earlier correct maintenance is the best insurance against the development of defects.

Problem	Cause	Measures
Motor starts but drum stands still	Belts off	Replace belts
Motor protector fuses or motor sluggish (high power consumption)	<ul style="list-style-type: none"> ♦ Blown fuse ♦ Motor fault ♦ Excess feed ♦ Solid particles have piled up in centrifuge housing 	<ul style="list-style-type: none"> ♦ Check/replace fuse ♦ Replace motor ♦ Check that feed is not higher than indicated in order document ♦ Clean housing and check that free outlet is available for coolant and swarf
Too much swarf in coolant outlet	Worn or deformed screen	Replace screen
Too high level of residual moisture in centrifuged swarf	<ul style="list-style-type: none"> ♦ Screen blocked ♦ Screen damaged ♦ Excess feed 	<ul style="list-style-type: none"> ♦ Clean screen ♦ Replace screen ♦ Check that feed is not higher than indicated in order document
To high level of vibration	<ul style="list-style-type: none"> ♦ Worn bearings ♦ Screen damaged by component and swarf has collected at damage location ♦ Worn drum 	<ul style="list-style-type: none"> ♦ Replace bearing ♦ Replace screen ♦ Replace drum

Spare parts list

NB! When ordering spare parts, please specify the following data:

- Type
- Serial number
- Designation
- Article number

Pos	Article No.	Designation	Qty	Unit
1	970601	Vibration absorber	3 pcs	Set
2	901510	Door		Pce
3	971619	Eccentric lock with hooks	6 pcs	Set
4	901522	Feed chute		Pce
5	901509	Seal ring		Pce
6	901518	Screen		Pce
7A	901529	Drum		Pce
7B		Drum stainless		Pce
8	901500	Housing		Pce
9	941512	Shaft washer		Pce
11	96101	Motor		Pce
13	901515	Belt protection		Pce
14	9702401	Pulley		Pce
15	9702301	V-belt	3 pcs	Set
16	9702402	Pulley		Pce
17	970159	Bearing		Pce
18	941514	Shaft		Pce
19	970158	Bearing		Pce
20	901524	Discharge		Pce
21A	95254	Interlocking breaker		Pce
21B	95220	Key with movable hold		Pce
22	95235	Rotation guard		Pce
23	970711	Rubber - swarf outlet		Pce
24	970715	Rubber - coolant outlet		Pce
-	970716	Rubber - swarf inlet		Pce
25	970713	Rubber clamp - straight		m
26	970714	Rubber clamp - bend		Pce

Drawing – spare parts

